

On the asymmetric clocked buffered switch

J.W. Cohen

CWI, P.O. Box 94079, 1090 GB Amsterdam, The Netherlands

Received 19 September 1997; revised 7 June 1998

A 2×2 clocked buffered switch is a device used in data-processing networks for routing messages from one node to another. The message handling process of this switch can be modelled as a two-server, time slotted, queueing process with state space the number of messages (x_n, y_n) present at the servers at the end of a time slot. The (x_n, y_n) -process is a two-dimensional nearest-neighbour random walk. In the present study the bivariate generating function $\Phi(p, q)$ of the stationary distribution of this random walk is determined, assuming that this distribution exists. $\Phi(p, q)$ is known, whenever $\Phi(p, 0)$ and $\Phi(0, q)$ are known. The essential points of the present study are the construction of these two functions from the knowledge of their poles and zeros and the simple determination of these poles and zeros.

Keywords: nearest-neighbour random walk, two-dimensional meromorphic functions, analytic continuation, two-server queueing model

1. Introduction

The 2×2 clocked buffered switch is modelled by a two-server queueing system with two arrival streams. The adjective “clocked” refers to a time-slotted operation, i.e., in a unit time interval each arrival stream can generate only one arrival and each server can serve only one customer. Consider the n th time slot. Denote by x_n and y_n the numbers of customers present at the first and at the second service facility just before the start of the n th time slot. The structure of the stochastic process (x_n, y_n) , $n = 1, 2, \dots$, is described by

$$x_{n+1} = [x_n - 1]^+ + \xi_n, \quad y_{n+1} = [y_n - 1]^+ + \eta_n, \quad (1.1)$$

with ξ_n and η_n the number of arrivals at the first and second service facility during the $(n - 1)$ th time slot.

The arrival process (ξ_n, η_n) , $n = 1, 2, \dots$, is characterized as follows. Each arrival stream generates at the start of a slot at most one arrival and this with probability a_1 for a stream 1, and with probability a_2 for stream 2, $0 < a_i < 1$, $i = 1, 2$. For each stream the arrivals in successive time slots are independent events, also the 1-arrivals and the 2-arrivals are stochastically independent. Let r_{ij} , $i = 1, 2$; $j = 1, 2$, be the probability that an i -arrival joins the queue of the j th service facility, see figure 1; and these arrivals choose the service facility independently of each other.

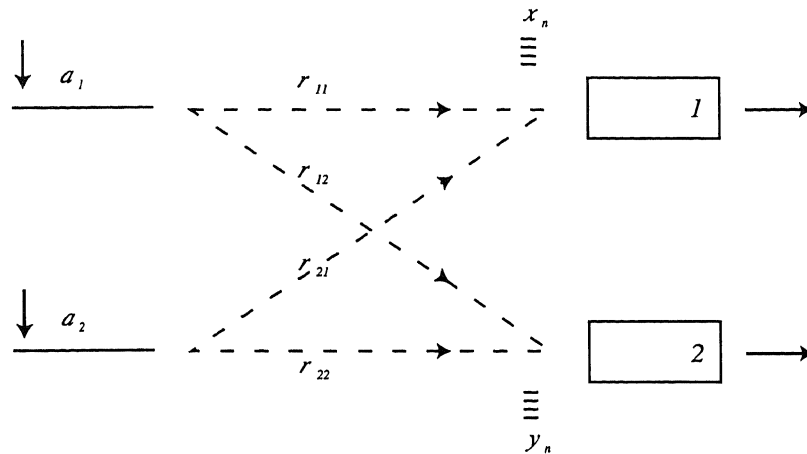

Figure 1.

So we have for the asymmetrical model

$$\begin{aligned} r_{11} + r_{12} &= 1, & 0 < a_1 < 1, & 0 < r_{11} < 1, \\ r_{21} + r_{22} &= 1, & 0 < a_2 < 1, & 0 < r_{22} < 1, \\ |a_1 - a_2| + |r_{11} - r_{22}| &\neq 0. \end{aligned} \quad (1.2)$$

A simple calculation shows that the bivariate generating function $\phi(p, q)$ of the distribution of (ξ_n, η_n) is given by

$$\phi(p, q) = E\{p^{\xi_n} q^{\eta_n}\} = [1 - a_1 + a_1(r_{11}p + r_{12}q)][1 - a_2 + a_2(r_{21}p + r_{22}q)]. \quad (1.3)$$

The stochastic process $(\mathbf{x}_n, \mathbf{y}_n)$, $n = 1, 2, \dots$, is well defined by (1.1) and (1.3). Obviously, it is a two-dimensional Markov chain with state space

$$S := \{0, 1, 2, \dots\} \times \{0, 1, 2, \dots\},$$

the set of integer-valued lattice points with non-negative coordinates.

This Markov chain is positive recurrent if and only if

$$E\{\xi_n\} = a_1 r_{11} + a_2 r_{21} < 1, \quad E\{\eta_n\} = a_1 r_{12} + a_2 r_{22} < 1. \quad (1.4)$$

The condition (1.4) is intuitively clear because $E\{\xi_n\}$ denotes the traffic load of server 1, $E\{\eta_n\}$ that of server 2. For a proof, see [2, theorem II.2.6.1, p. 95].

In the present study it will always be assumed that (1.4) applies. Hence, the $(\mathbf{x}_n, \mathbf{y}_n)$ -process possesses a stationary distribution. Let (\mathbf{x}, \mathbf{y}) be a pair of non-negative stochastic variables with joint distribution the stationary distribution of the $(\mathbf{x}_n, \mathbf{y}_n)$ -process. Introduce the generating function: for $|p| \leq 1$, $|q| \leq 1$,

$$\Phi(p, q) := E\{p^{\mathbf{x}} q^{\mathbf{y}}\}. \quad (1.5)$$

From (1.2), (1.3) and (1.5) it is readily derived that $\Phi(p, q)$ should satisfy: for $|p| \leq 1$, $|q| \leq 1$,

- (i) $[pq - \phi(p, q)]\Phi(p, q) = (p - 1)(q - 1)\phi(p, q) \left[\Phi(0, 0) + \frac{\Phi(p, 0)}{p - 1} + \frac{\Phi(0, q)}{q - 1} \right]$,
- (ii) $\Phi(p, q)$ is a bivariate generating function of a true probability distribution on S .

Remark 1.1. The relation (1.6)(i) is equivalent with the Kolmogorov equations for the stationary state probabilities of the $(\mathbf{x}_n, \mathbf{y}_n)$ -process. These equations have one and only one absolutely convergent solution apart from a constant factor, and consequently there exists only one function $\Phi(p, q)$ which satisfies (1.6)(i), (ii), and $\Phi(1, 1) = 1$.

Remark 1.2. In [1,6] the 2×2 clocked buffered switch is modelled by the Markov chain with structure

$$\hat{\mathbf{x}}_{n+1} = [\hat{\mathbf{x}}_n - 1 + \hat{\xi}_n]^+, \quad \hat{\mathbf{y}}_{n+1} = [\hat{\mathbf{y}}_n - 1 + \hat{\eta}_n]^+. \tag{1.7}$$

Here, $\hat{\mathbf{x}}_n, \hat{\mathbf{y}}_n$ are the number of customers present immediately after the start of the n th time slot and $\hat{\xi}_n, \hat{\eta}_n$ are the arrivals during this time slot. With $\Psi(p, q)$, $|p| \leq 1$, $|q| \leq 1$, the bivariate generating function of the stationary distribution of the $(\hat{\mathbf{x}}_n, \hat{\mathbf{y}}_n)$ -process the functional equation for $\Psi(p, q)$ reads: for $|p| \leq 1$, $|q| \leq 1$,

$$[pq - \phi(p, q)]\Psi(p, q) = (p - 1)(q - 1) \left[\phi(0, 0)\Psi(0, 0) + \frac{\phi(p, 0)}{p - 1}\Psi(p, 0) + \frac{\phi(0, q)}{q - 1}\Psi(0, q) \right]. \tag{1.8}$$

Comparison of (1.6) and (1.8) shows that

$$\Phi(p, q) = \phi(p, q)\Psi(p, q), \quad |p| \leq 1, \quad |q| \leq 1.$$

The present model stems from performance analysis for a data processing model for routing of messages in computer architectures. The symmetric model (i.e., $a_1 = a_2$, $r_{ij} = \frac{1}{2}$, $i = 1, 2$, $j = 1, 2$) has been analysed by Jaffe [6], in a slightly different setting. In his analysis he applies the uniformisation technique from the theory of complex functions to determine the bivariate generating function of the stationary distribution. Boxma and Van Houtem [1] have analysed the asymmetric model by using the compensation technique, which is an iterative procedure to solve (numerically) the relevant Kolmogorov equations for the stationary distribution. In their study they briefly discuss the analysis of the problem by formulating it as a boundary value problem. The present author has investigated the symmetrical model in [5]. Here, as in [6], an explicit analytic representation is derived, by showing that $\Phi(p, 0)$ and $\Phi(0, q)$ are both meromorphic functions, i.e., they are analytic functions except for a finite number of poles in every finite domain. In [6] these functions are characterised by their poles and the residues at these poles apart from a finite polynome. In [5] these functions are determined directly via their zeros and their poles. This approach

avoids the uniformisation technique. In the present study it is shown that the approach developed in [5] can be also applied successfully in the analysis of the asymmetrical model. For a similar approach see also [3].

In sections 2–4 the determination of the functions $\Phi(p, 0)$ and $\Phi(0, q)$ is described, once they are known then $\Phi(p, q)$ follows from (1.6)(i). In section 2 a functional equation for $\Phi(p, 0)$ and $\Phi(0, q)$ is derived from (1.6)(i) by using the zero-tuples of the kernel $K(p, q) := pq - \phi(p, q)$, see, for some properties of these zero-tuples, appendix A. Starting from this functional equation it is shown that $\Phi(p, 0)$ and $\Phi(0, p)$ are meromorphic functions with all poles in $|p| > 1$. All these poles are simple and their location is readily obtained by a simple recursive relation.

In section 3 the zeros of $\Phi(p, 0)$ and $\Phi(0, q)$ are determined again from the functional relation derived in section 2. All zeros are simple and again they are determined by a recursive algorithm.

In section 4 explicit expressions for the functions $\Phi(p, 0)$ and $\Phi(0, q)$ are derived, and it is shown that they determine the unique solution of (1.6).

2. Analysis of the functional equation, I

To construct the solution of the functional equation (1.6) we need properties of the zero-tuples of the kernel $K(p, q)$ which is defined by

$$K(p, q) = pq - E\{p^{\xi}q^{\eta}\} = pq - \phi(p, q). \quad (2.1)$$

These properties are derived in appendix A.

The definition of $\Phi(p, q)$ implies that

- (i) $|\Phi(\bar{p}, \bar{q})| < \infty$ for every zero-tuple (\bar{p}, \bar{q}) of $K(p, q)$ with $|p| \leq 1$, $|q| \leq 1$,
- (ii) $\Phi(p, 0)/\Phi(1, 0)$ is regular for $|p| < 1$, continuous for $|p| \leq 1$, and it is a generating function of a probability distribution; analogously for $\Phi(0, q)/\Phi(0, 1)$.

In appendix A it is shown, cf. (A.17), with $P_{1,2}(q)$ the two zeros of $K(p, q)$ for given q that

$$\text{for } |q| \geq 1, q \neq 1, \quad |P_1(q)| < |q| < |P_2(q)|. \quad (2.3)$$

Hence, from the functional equation (1.6)(i) we have

$$\text{for } |q| = 1, q \neq 1, \quad \frac{\Phi(P_1(q), 0)}{P_1(q) - 1} + \frac{\Phi(0, q)}{q - 1} + \Phi(0, 0) = 0; \quad (2.4)$$

analogously, cf. (A.18),

$$\text{for } |p| = 1, p \neq 1, \text{ with } |Q_1(p)| < |p| < |Q_2(p)|, \\ \frac{\Phi(p, 0)}{p - 1} + \frac{\Phi(0, Q_1(p))}{Q_1(p) - 1} + \Phi(0, 0) = 0. \quad (2.5)$$

We start the analysis of this equation by considering figure 2.

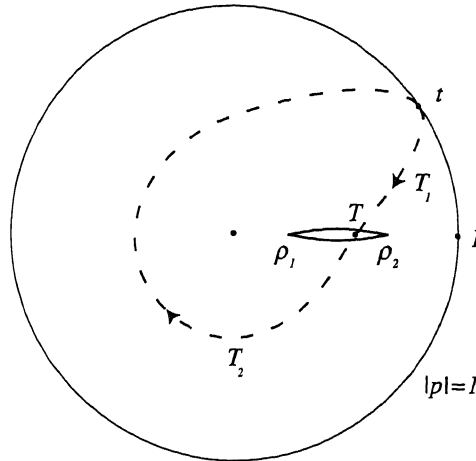

Figure 2.

Here, $T_1 \cup \{T\} \cup T_2$ is a simple, analytic contour which intersects the open interval (ρ_1, ρ_2) only once; ρ_1, ρ_2 are the only branch points of $Q_{1,2}(p)$, cf. (A.20) and (A.21); the point t is on the unit circle, it is the begin- and endpoint of the contour, which lies inside the unit disk $|p| < 1$ except for the point t . From (2.2)(ii) it is seen that $\Phi(p, 0)/(p - 1)$ is regular in $|p| < 1$, and so it is regular on the contour $(T_1 \cup \{T\} \cup T_2) \setminus \{t\}$ and continuous on $T_1 \cup \{T\} \cup T_2$. Hence, (2.5) implies that $\Phi(0, Q_1(p)/\{Q_1(p) - 1\})$ has an analytic continuation along this contour. Next, note that $Q_1(p)$ when continued out from t along T_1 has on T_2 the analytic continuation $Q_2(p)$, because $T \in (\rho_1, \rho_2)$ and $\overline{Q_1(p)} = Q_2(p)$ for $p \in (\rho_1, \rho_2)$. Further, (2.2)(ii) implies that $\overline{Q(0, q)} = Q(0, \bar{q})$. Hence, the analytic continuation of (2.5) along the contour yields

$$\text{for } |p| = 1, p \neq 1, \quad \frac{\Phi(p, 0)}{p - 1} + \frac{\Phi(0, Q_2(p))}{Q_2(p) - 1} + \Phi(0, 0) = 0. \tag{2.6}$$

An analogous conclusion is obtained by starting from (2.4), but then the branch points τ_1, τ_2 of $P_{1,2}(q)$ should be used, cf. (A.20), (A.21); it is then found that

$$\text{for } |q| = 1, q \neq 1, \quad \frac{\Phi(P_2(q), 0)}{P_2(q) - 1} + \frac{\Phi(0, q)}{q - 1} + \Phi(0, 0) = 0. \tag{2.7}$$

From (2.3) and (A.9) we have

$$|P_2(q)| > 1 \quad \text{on } |q| = 1, \quad |Q_2(p)| > 1 \quad \text{on } |p| = 1. \tag{2.8}$$

Rewrite (2.6) as: for $|p| = 1, p \neq 1$,

$$(p - 1)\Phi(0, Q_2(p)) = -[\Phi(0, 0)(p - 1) + \Phi(p, 0)](Q_2(p) - 1). \tag{2.9}$$

The right-hand side of (2.9) is obviously finite for $p = 1$, cf. (2.1)(ii) and note that (A.9) implies $\infty > Q_2(1) > 1$. Consequently, by letting $p \rightarrow 1$ along $|p| = 1$, it follows that

$$\begin{aligned} \Phi(0, q) \text{ has a single pole at } q = Q_2(1), \\ \Phi(p, 0) \text{ has a single pole at } p = P_2(1), \end{aligned} \tag{2.10}$$

the second statement of (2.10) is analogously shown. Because the arguments above apply for every contour $T_1 \cup \{T\} \cup T_2$ it is seen from (2.2)(ii) that

$$\Phi(p, 0) \text{ is regular for } |p| < P_2(1), \quad \Phi(0, q) \text{ is regular for } |q| < Q_2(1). \tag{2.11}$$

Consider again the relation (2.5) multiplied by $p - 1$, cf. also (2.9). Because $\Phi(p, 0)$ is regular for $|p| < P_2(1)$, cf. (2.11), it follows that $\Phi(0, Q_1(p))$ can be continued analytically out from $|p| \leq 1$ into $\{p : 1 \leq |p| < P_2(1)\}$, note that the following limit exists:

$$0 < \left| \lim_{p \rightarrow 1} \frac{Q_1(p) - 1}{p - 1} \right| = \left| \frac{d}{dp} Q_1(p) \right|_{p=1} < \infty. \tag{2.12}$$

With

$$0 < \varepsilon < P_2(1) - 1, \tag{2.13}$$

define

$$\hat{p} = P_2(1) - \varepsilon, \tag{2.14}$$

and consider again an analytic, simple contour $T_1 \cup \{T\} \cup T_2$ with begin- and endpoint t , which intersects the interval (ρ_1, ρ_2) cf. (A.19), only once, with $p = 1 \notin T_2$, and which lies in $|p| < \hat{p}$ except for $p = t$, see figure 3.

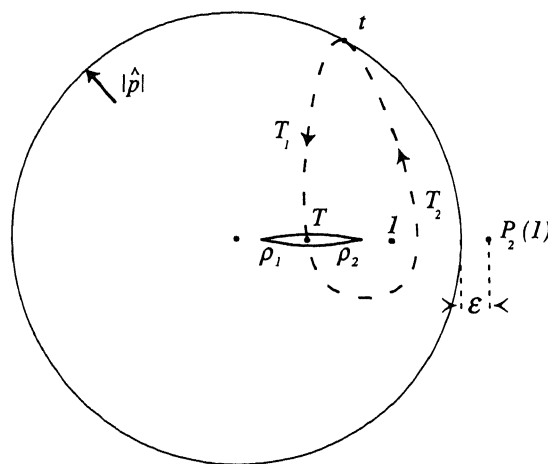

Figure 3.

The relation

$$\frac{\Phi(p, 0)}{p - 1} + \frac{\Phi(0, Q_1(p))}{Q_1(p) - 1} + \Phi(0, 0) = 0,$$

which holds for $|p| = \hat{p}$, may be continued analytically along $T_1 \cup \{T\} \cup T_2$ in the direction as shown in figure 3, and as above, cf. the derivation of (2.6), we obtain for every p with $|p| = |\hat{p}|$,

$$\frac{\Phi(p, 0)}{p - 1} + \frac{\Phi(0, Q_2(p))}{Q_2(p) - 1} + \Phi(0, 0) = 0. \tag{2.15}$$

Note that, cf. (A.18),

$$p \in T_2 \text{ and } 1 \notin T_2 \Rightarrow Q_2(p) \neq Q_2(1), \quad p \in T_2. \tag{2.16}$$

Consequently,

$$\Phi(0, Q_2(p)) \text{ is regular for every } p = \hat{p}. \tag{2.17}$$

Consider figure 4, where a part of the right branch of the hyperbola $K(p, q) = 0$, p and q real, has been traced.

The above analytic continuation of $\Phi(0, Q_2(p))$ holds for every contour as defined above with $|t| = |\hat{p}|$ and $1 \notin T_2$. Because

$$P_1(Q_2(1)) = 1 \quad \text{and} \quad q = Q_2(1) < Q_2(\hat{p}) < Q_2(P_2(1)), \tag{2.18}$$

and $Q_2(1)$ is a pole of $\Phi(0, q)$, cf. (2.10), it follows that

$$\Phi(0, Q_2(p)) \text{ is meromorphic for } |p| < |\hat{p}|. \tag{2.19}$$

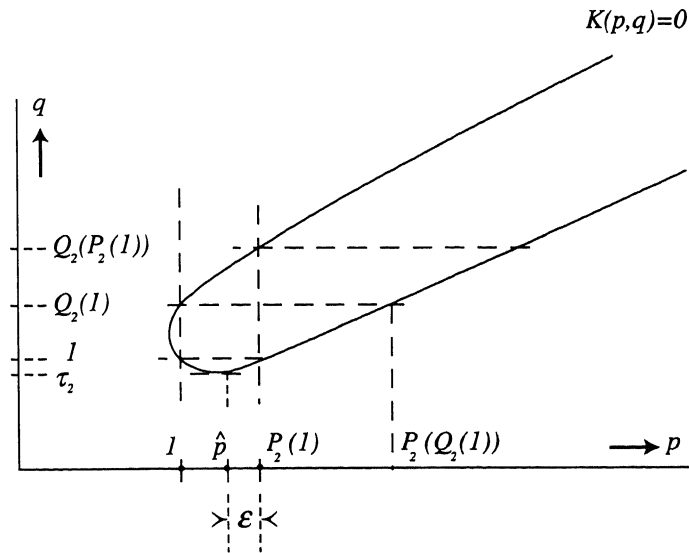

Figure 4.

Next we let $\varepsilon \rightarrow 0$ so that $\hat{p} \rightarrow P_2(1)$, it then follows from (2.15), because $p = P_2(1)$ is a single pole of $\Phi(p, 0)$, cf. (2.10), that

$$\begin{aligned} \Phi(0, q) \text{ has a single pole at } q &= Q_2(P_2(1)), \\ \Phi(p, 0) \text{ has a single pole at } p &= P_2(Q_2(1)), \end{aligned} \quad (2.20)$$

note that the proof of the second statement in (2.20) is analogous to that of the first statement.

By the same procedure as just discussed it is shown that $\Phi(0, q)$, and analogously, $\Phi(p, 0)$ can be continued meromorphically in $|q| \geq 1$ and $|p| \geq 1$, respectively. To describe this continuation we first introduce some notation.

We define the sequence

$$q_0^{(I)}, p_1^{(I)}, q_1^{(I)}, p_2^{(I)}, \dots, p_n^{(I)}, q_n^{(I)}, p_{n+1}^{(I)}, \dots,$$

recursively by

$$\begin{aligned} q_0^{(I)} &:= 1, \\ p_1^{(I)} &:= P_2(q_0^{(I)}), & p_1^{(I)} &> q_0^{(I)}, \\ q_1^{(I)} &:= Q_2(p_1^{(I)}), & q_1^{(I)} &> p_1^{(I)}, \\ p_2^{(I)} &:= P_2(q_1^{(I)}), & p_2^{(I)} &> q_1^{(I)}, \\ &\vdots & &\vdots \\ p_n^{(I)} &:= P_2(q_{n-1}^{(I)}), & p_n^{(I)} &> q_{n-1}^{(I)}, \\ q_n^{(I)} &:= Q_2(p_n^{(I)}), & q_n^{(I)} &> p_n^{(I)}, \\ &\vdots & &\ddots \end{aligned} \quad (2.21)$$

The geometrical structure of this sequence is shown in figure 5; note that the inequalities in (2.21) stem from (2.3), see also (A.17) and (A.18).

Analogously, we construct the sequence

$$p_0^{(II)}, q_1^{(II)}, p_1^{(II)}, q_2^{(II)}, \dots, q_n^{(II)}, p_n^{(II)}, q_{n+1}^{(II)}, \dots,$$

recurrently by

$$\begin{aligned} p_0^{(II)} &:= 1, \\ q_1^{(II)} &:= Q_2(p_0^{(II)}), & q_1^{(II)} &> p_0^{(II)}, \\ p_1^{(II)} &:= P_2(q_1^{(II)}), & p_1^{(II)} &> q_1^{(II)}, \\ q_2^{(II)} &:= Q_2(p_1^{(II)}), & q_2^{(II)} &> p_1^{(II)}, \\ &\vdots & &\vdots \\ q_n^{(II)} &:= Q_2(p_{n-1}^{(II)}), & q_n^{(II)} &> p_{n-1}^{(II)}, \\ p_n^{(II)} &:= P_2(q_n^{(II)}), & p_n^{(II)} &> q_n^{(II)}, \\ &\vdots & &\ddots \end{aligned} \quad (2.22)$$

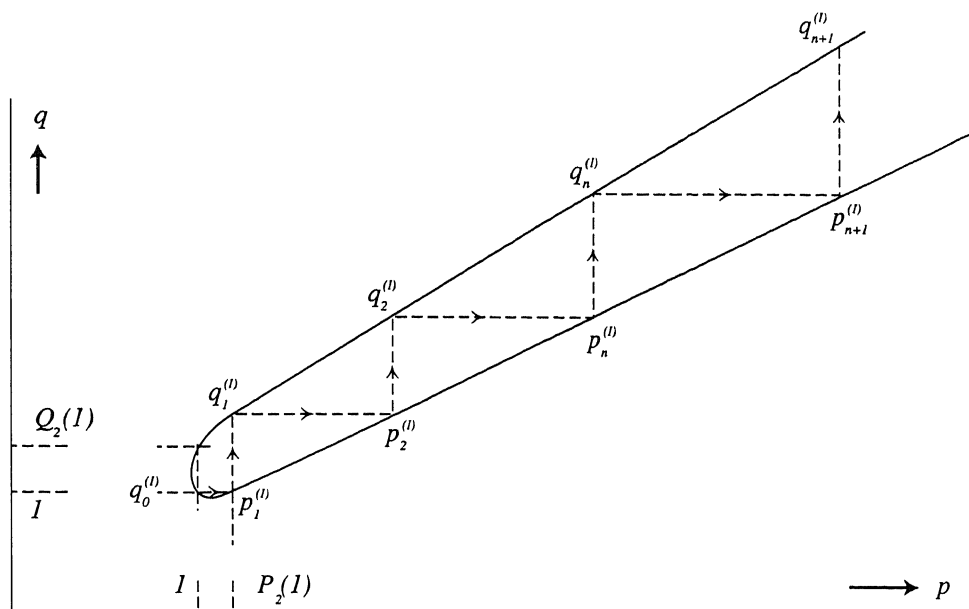

Figure 5.

From (2.10) and (2.20) and by repeatedly performing the meromorphic continuation as used in the derivation of (2.20) it is seen that

$$\begin{aligned} \Phi(0, q) \text{ has simple poles at } q_n^{(I)}, \quad n = 1, 2, \dots, \\ \Phi(p, 0) \text{ has simple poles at } p_n^{(I)}, \quad n = 1, 2, \dots \end{aligned} \tag{2.23}$$

By using the symmetry, it is seen that

$$\begin{aligned} \Phi(p, 0) \text{ has simple poles at } p_n^{(II)}, \quad n = 1, 2, \dots, \\ \Phi(0, q) \text{ has simple poles at } q_n^{(II)}, \quad n = 1, 2, \dots \end{aligned} \tag{2.24}$$

By noting that both asymptotes of the hyperbola have positive slope less than 90° , cf. (A.12), it is seen that for $n \rightarrow \infty$,

$$q_n^{(i)} \rightarrow \infty, \quad p_n^{(i)} \rightarrow \infty, \quad i = I, II. \tag{2.25}$$

Put

$$\delta_1 := \lim_{n \rightarrow \infty} \frac{q_n^{(I)}}{p_n^{(I)}} > 1, \quad \delta_2 := \lim_{n \rightarrow \infty} \frac{p_n^{(II)}}{q_n^{(II)}} > 1, \tag{2.26}$$

then it is readily seen from (A.1) that δ_1 is the larger zero of

$$a_1 a_2 r_{12} r_{22} z^2 + [-1 + a_1 a_2 (r_{11} r_{22} + r_{21} r_{12})] z + a_1 a_2 r_{11} r_{21} = 0, \tag{2.27}$$

and that δ_2 is the larger root of the quadratic equation in ξ , obtained from (2.27) by substituting $z = \xi^{-1}$, so that δ_2^{-1} is the smaller root of (2.27).

The meromorphic continuation described above shows that for every zero-tuple (\hat{p}, \hat{q}) of $K(p, q)$ holds:

$$\frac{\Phi(\hat{p}, 0)}{\hat{p} - 1} + \frac{\Phi(0, \hat{q})}{\hat{q} - 1} + \Phi(0, 0) = 0,$$

if \hat{p} is not a pole of $\Phi(p, 0)$ and \hat{q} not a pole of $\Phi(0, q)$.

Put for $i = I, II; n = 1, 2, \dots$,

$$\omega_n^{(i)} := \lim_{p \rightarrow p_n^{(i)}} (p - p_n^{(i)}) \Phi(p, 0), \quad \psi_n^{(i)} := \lim_{q \rightarrow q_n^{(i)}} (q - q_n^{(i)}) \Phi(0, q), \quad (2.28)$$

it then follows from the analysis above by noting that all poles in (2.23) and (2.24) are simple poles that: for $i = I, II; n = 1, 2, \dots$,

$$\begin{aligned} \lim_{p \rightarrow p_n^{(i)}} (p - p_n^{(i)}) \left[\frac{\Phi(p, 0)}{p - 1} + \frac{\Phi(0, Q_1(p))}{Q_1(p) - 1} + \Phi(0, 0) \right] &= 0, \\ \lim_{p \rightarrow p_n^{(i)}} (p - p_n^{(i)}) \left[\frac{\Phi(p, 0)}{p - 1} + \frac{\Phi(0, Q_2(p))}{Q_2(p) - 1} + \Phi(0, 0) \right] &= 0. \end{aligned} \quad (2.29)$$

From the definition of $Q_{1,2}(p)$, cf. appendix A, we have for a zero-tuple (p, q) with $q = Q_{1,2}(p)$,

$$q - q_{n-1}^{(I)} = Q_1(p) - Q_1(p_n^{(I)}), \quad q - q_n^{(I)} = Q_2(p) - Q_2(p_n^{(I)}). \quad (2.30)$$

From (2.28)–(2.30) we obtain

$$\begin{aligned} \frac{\omega_n^{(I)}}{p_n^{(I)} - 1} + \left[\frac{d}{dp} Q_1(p) \right]_{p=p_n^{(I)}}^{-1} \frac{\psi_{n-1}^{(I)}}{Q_1(p_{n-1}^{(I)}) - 1} &= 0, \quad n = 2, 3, \dots, \\ \frac{\omega_n^{(I)}}{p_n^{(I)} - 1} + \left[\frac{d}{dp} Q_2(p) \right]_{p=p_n^{(I)}}^{-1} \frac{\psi_n^{(I)}}{Q_2(p_n^{(I)}) - 1} &= 0, \quad n = 1, 2, \dots, \\ \Phi(1, 0) + \left[\frac{d}{dp} Q_2(p) \right]_{p=p_1^{(I)}}^{-1} \frac{\psi_1^{(I)}}{Q_2(p_1^{(I)}) - 1} &= 0. \end{aligned} \quad (2.31)$$

Analogously, we have

$$\begin{aligned} \frac{\psi_n^{(II)}}{q_n^{(II)} - 1} + \left[\frac{d}{dq} P_1(q) \right]_{q=q_n^{(II)}}^{-1} \frac{\omega_{n-1}^{(II)}}{P_1(q_{n-1}^{(II)}) - 1} &= 0, \quad n = 1, 2, \dots, \\ \frac{\psi_n^{(II)}}{q_n^{(II)} - 1} + \left[\frac{d}{dq} P_2(q) \right]_{q=q_n^{(II)}}^{-1} \frac{\omega_n^{(II)}}{P_2(q_n^{(II)}) - 1} &= 0, \quad n = 1, 2, \dots, \\ \Phi(0, 1) + \left[\frac{d}{dq} P_2(q) \right]_{q=q_1^{(II)}}^{-1} \frac{\omega_1^{(II)}}{P_2(q_1^{(II)}) - 1} &= 0. \end{aligned} \quad (2.32)$$

By means of the set of recurrent relations (2.31) all $\omega_n^{(I)}$, $n = 1, 2, \dots$, and all $\psi_n^{(I)}$, $n = 2, 3, \dots$, may be expressed in $\psi_1^{(I)}$, analogously for $\psi_n^{(II)}$, $n = 1, 2, \dots$, and $\omega_n^{(II)}$,

$n = 2, 3, \dots$. The residues $\psi_1^{(I)}$ and $\omega_1^{(I)}$ then have still to be determined. However, a meromorphic function is generally not completely determined by its poles and residues only; it is determined by these data apart from an additive polynomial. In the present study we shall refrain from the derivation of expressions for $\Phi(p, 0)$ and $\Phi(0, q)$ in terms of their poles and residues.

3. On the analysis of the functional equation, II

From the results obtained in the preceding section it is seen that $\Phi(p, 0)$, and similarly $\Phi(0, p)$, has a meromorphic continuation in $|p| > 1$ whenever $\Phi(p, q)$ satisfies (2.2). For this meromorphic continuation holds:

$$\frac{\Phi(\hat{p}, 0)}{\hat{p} - 1} + \frac{\Phi(0, \hat{q})}{\hat{q} - 1} + \Phi(0, 0) = 0, \tag{3.1}$$

for every zero-tuple (\hat{p}, \hat{q}) of $K(p, q)$ for which \hat{p} is not a pole of $\Phi(p, 0)$ and/or \hat{q} is not a pole of $\Phi(0, q)$; for \hat{p} or \hat{q} a pole see (2.29).

In this section we study the zeros of $\Phi(p, 0)$ and $\Phi(0, q)$. Consider the zero-tuple, cf. (A.8)),

$$(\hat{p}, \hat{q}) = (\alpha_0^{(I)}, 0) \quad \text{with} \quad \alpha_0^{(I)} := -\frac{1 - a_1}{a_1 r_{11}} < 0. \tag{3.2}$$

It then follows from (3.1) that

$$\Phi(\alpha_0^{(I)}, 0) = 0. \tag{3.3}$$

Note that $(\alpha_0^{(I)}, 0)$ is a point on the left branch of the hyperbola, see figure 7 of appendix A. So again with

$$|P_1(q)| < |q| < |P_2(q)|, \quad |q| \geq 1, \tag{3.4}$$

for the two zeros $p = P_{1,2}(q)$ of $K(p, q)$, we may put (without loss of generality, cf. (3.7) below)

$$\alpha_0^{(I)} := P_2(0). \tag{3.5}$$

The relation (3.1) may be rewritten as

$$\begin{aligned} \frac{\Phi(\hat{p}, 0)}{\hat{p} - 1} + \frac{\Phi(0, Q_2(\hat{p}))}{Q_2(\hat{p}) - 1} + \Phi(0, 0) &= 0, \quad \text{or} \\ \frac{\Phi(\hat{p}, 0)}{\hat{p} - 1} + \frac{\Phi(0, Q_1(\hat{p}))}{Q_1(\hat{p}) - 1} + \Phi(0, 0) &= 0, \end{aligned} \tag{3.6}$$

with

$$|Q_1(\hat{p})| < |\hat{p}| < |Q_2(\hat{p})|.$$

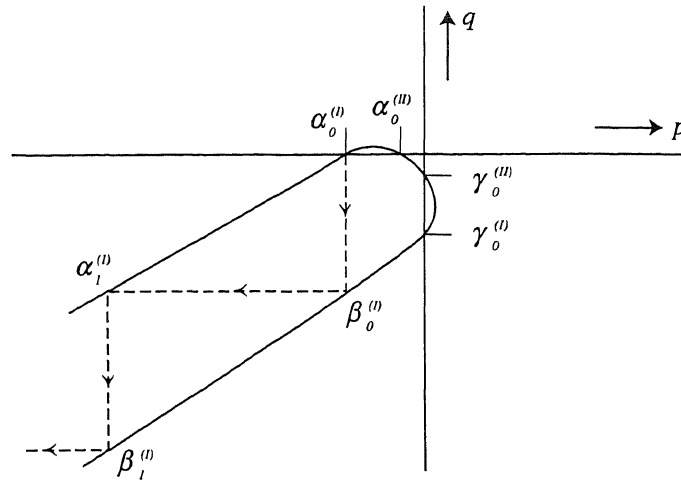

Figure 6.

Next consider figure 6. In this figure the left branch of the hyperbola $K(p, q) = 0$ is sketched. This hyperbola intersects the horizontal axis at the points $\alpha_0^{(I)}$ and $\alpha_0^{(II)}$, and the vertical axis at $\gamma_0^{(I)}$ and $\gamma_0^{(II)}$, see (A.8) for these points.

Their definition is chosen in such a way that

$$|\alpha_0^{(I)}| > |\alpha_0^{(II)}| \quad \text{and} \quad |\gamma_0^{(I)}| > |\gamma_0^{(II)}|. \tag{3.7}$$

For the case that (but cf. (1.2))

$$\alpha_0^{(I)} = \alpha_0^{(II)} \quad \text{and/or} \quad \gamma_0^{(I)} = \gamma_0^{(II)},$$

see remarks 3.1 and 4.1.

We introduce the sequence

$$\alpha_0^{(I)}, \beta_0^{(I)}, \alpha_1^{(I)}, \beta_1^{(I)}, \dots, \alpha_{n-1}^{(I)}, \beta_{n-1}^{(I)}, \alpha_n^{(I)}, \dots, \tag{3.8}$$

which is recursively defined by

$$\begin{aligned} \alpha_0^{(I)} &:= P_2(0) = -\frac{1 - a_1}{a_1 r_{11}} < 0, \\ \beta_0^{(I)} &:= Q_2(\alpha_0^{(I)}), & |\beta_0^{(I)}| &> |\alpha_0^{(I)}|, \\ \alpha_1^{(I)} &:= P_2(\beta_0^{(I)}), & |\alpha_1^{(I)}| &> |\beta_0^{(I)}|, \\ \beta_1^{(I)} &:= Q_2(\alpha_1^{(I)}), & |\beta_1^{(I)}| &> |\alpha_1^{(I)}|, \\ &\vdots & & \vdots \\ \beta_{n-1}^{(I)} &:= Q_2(\alpha_{n-1}^{(I)}), & |\beta_{n-1}^{(I)}| &> |\alpha_{n-1}^{(I)}|, \\ \alpha_n^{(I)} &:= P_2(\beta_{n-1}^{(I)}), & |\alpha_n^{(I)}| &> |\beta_{n-1}^{(I)}|, \\ &\vdots & & \vdots \end{aligned} \tag{3.9}$$

From (3.3) and (3.6) it is seen by using (3.9) that

$$\frac{\Phi(0, \beta_0^{(I)})}{\beta_0^{(I)} - 1} + \Phi(0, 0) = 0. \tag{3.10}$$

From (3.6) and (3.9) we have

$$\frac{\Phi(\alpha_1^{(I)}, 0)}{\alpha_1^{(I)} - 1} + \frac{\Phi(0, \beta_0^{(I)})}{\beta_0^{(I)} - 1} + \Phi(0, 0) = 0, \tag{3.11}$$

and, hence, from (3.10) and (3.11),

$$\Phi(\alpha_1^{(I)}, 0) = 0. \tag{3.12}$$

Repeating this derivation it is readily seen that

$$\Phi(p, 0) \text{ has simple zeros at } p = \alpha_n^{(I)}, \quad n = 0, 1, 2, \dots, \tag{3.13}$$

note that $\alpha_0^{(I)}$ is a simple zero of $K(p, 0)$, cf. (3.7). With initial point $\alpha_0^{(II)}$ the sequence

$$\alpha_0^{(II)}, \beta_0^{(II)}, \alpha_1^{(II)}, \beta_1^{(II)}, \dots, \alpha_{n-1}^{(II)}, \beta_{n-1}^{(II)}, \alpha_n^{(II)}, \dots, \tag{3.14}$$

is defined completely similarly as the sequence in (3.8), the super index I in (3.9) is replaced by II . As before it follows that

$$\Phi(p, 0) \text{ has simple zeros at } p = \alpha_n^{(II)}, \quad n = 0, 1, 2, \dots \tag{3.15}$$

Remark 3.1. If $\alpha_0^{(I)} = \alpha_0^{(II)}$, so that $\alpha_0^{(I)}$ is a zero of multiplicity two of $K(p, 0)$ then the sequences in (3.8) and (3.14) are identical and the $\alpha_n^{(I)}$ are zeros with multiplicity two of $\Phi(p, 0)$.

With initial point $\gamma_0^{(I)}$, the sequence

$$\gamma_0^{(I)}, \delta_0^{(I)}, \gamma_1^{(I)}, \delta_1^{(I)}, \dots, \delta_{n-1}^{(I)}, \gamma_{n-1}^{(I)}, \delta_{n-1}^{(I)}, \dots, \tag{3.16}$$

is recursively defined by

$$\delta_{n-1}^{(I)} := P_2(\gamma_{n-1}^{(I)}), \quad \gamma_n^{(I)} := Q_2(\delta_{n-1}^{(I)}), \quad n = 1, 2, \dots, \tag{3.17}$$

and analogously to the derivation of (3.8) it is shown that

$$\Phi(0, q) \text{ has simple zeros at } q = \gamma_n^{(I)}, \quad n = 0, 1, 2, \dots \tag{3.18}$$

With initial point $\gamma_0^{(II)}$ the sequence

$$\gamma_0^{(II)}, \delta_0^{(II)}, \gamma_1^{(II)}, \delta_1^{(II)}, \dots, \delta_{n-1}^{(II)}, \gamma_{n-1}^{(II)}, \delta_n^{(II)}, \dots, \tag{3.19}$$

is defined by the same recurrent relations as in (3.17); and similarly it is shown that

$$\Phi(0, q) \text{ has simple zeros at } q = \gamma_n^{(II)}, \quad n = 0, 1, 2, \dots \tag{3.20}$$

Remark 3.2. If $\gamma_0^{(I)} = \gamma_0^{(II)}$ then as in remark 3.1, the $\gamma_n^{(I)}$ are zeros of multiplicity two of $\Phi(0, q)$.

As in section 2, cf. (2.25) and (2.26), it is shown that for $i = I, II$

$$\alpha_n^{(i)} \rightarrow -\infty, \quad \beta_n^{(i)} \rightarrow -\infty; \quad \gamma_n^{(i)} \rightarrow -\infty, \quad \delta_n^{(i)} \rightarrow -\infty, \quad (3.21)$$

and

$$\frac{\beta_n^{(i)}}{\alpha_n^{(i)}} \rightarrow \delta_1 > 1, \quad \frac{\delta_n^{(i)}}{\gamma_n^{(i)}} \rightarrow \delta_2 > 1.$$

4. The expression for $\Phi(p, 0)$ and for $\Phi(0, q)$

In section 2 we have shown that $\Phi(p, 0)$ and $\Phi(0, q)$ are meromorphic, a result which stems from the conditions (1.6) to be satisfied by $\Phi(p, q)$, $|p| \leq 1$, $|q| \leq 1$. In section 2 we have located the poles of $\Phi(p, 0)$ and $\Phi(0, q)$, cf. (2.23) and (2.24), and in section 3 their zeros, cf. (3.13), (3.15), (3.18) and (3.20). From the analysis in section 2 it is seen that the indicated poles are the only poles. However, the analysis in section 3 does not show that the indicated zeros are the only zeros. Actually, they are the only zeros. A direct proof of this statement is not so simple, but is also not needed, as it will be shown below, see remark 4.2.

Define, cf. (2.23) and (2.24),

$$\begin{aligned} P^{(I)}(p) &:= \prod_{n=1}^{\infty} \left(1 - \frac{p}{p_n^{(I)}}\right), & P^{(II)}(p) &:= \prod_{n=1}^{\infty} \left(1 - \frac{p}{p_n^{(II)}}\right), \\ Q^{(I)}(q) &:= \prod_{n=1}^{\infty} \left(1 - \frac{q}{q_n^{(I)}}\right), & Q^{(II)}(q) &:= \prod_{n=1}^{\infty} \left(1 - \frac{q}{q_n^{(II)}}\right), \end{aligned} \quad (4.1)$$

and, cf. (3.13), (3.15), (3.18) and (3.20),

$$\begin{aligned} A^{(I)}(p) &:= \prod_{n=0}^{\infty} \left(1 - \frac{p}{\alpha_n^{(I)}}\right); & A^{(II)}(p) &:= \prod_{n=0}^{\infty} \left(1 - \frac{p}{\alpha_n^{(II)}}\right), \\ \Gamma^{(I)}(q) &:= \prod_{n=0}^{\infty} \left(1 - \frac{q}{\gamma_n^{(I)}}\right); & \Gamma^{(II)}(q) &:= \prod_{n=0}^{\infty} \left(1 - \frac{q}{\gamma_n^{(II)}}\right). \end{aligned} \quad (4.2)$$

Because of (2.26) the infinite products in (4.1) are for finite p and q absolutely convergent and so are well defined; note that (2.26) implies that for N sufficiently large

$$\left| \frac{p_{N+n}^{(i)}}{p_N^{(i)}} \right| \sim C(\delta_1 \delta_2)^n, \quad n = 1, 2, \dots; \quad i = (I, II), \quad (4.3)$$

with C independent of n ; analogously for $q_{N+n}^{(i)}/q_N^{(i)}$. Similarly, the infinite products in (4.2) are well defined. We next show that for the function $\Phi(p, q)$ satisfying the conditions (1.6) holds:

$$\begin{aligned} \text{(i)} \quad \Phi(p, 0) &= \Phi(1, 0) \frac{P^{(I)}(1)P^{(II)}(1) A^{(I)}(p)A^{(II)}(p)}{P^{(I)}(p)P^{(II)}(p) A^{(I)}(1)A^{(II)}(1)}, \quad \text{for all } p, \\ \text{(ii)} \quad \Phi(0, q) &= \Phi(0, 1) \frac{Q^{(I)}(1)Q^{(II)}(1) \Gamma^{(I)}(q)\Gamma^{(II)}(q)}{Q^{(I)}(q)Q^{(II)}(q) \Gamma^{(I)}(1)\Gamma^{(II)}(1)}, \quad \text{for all } q. \end{aligned} \tag{4.4}$$

Proof. Because of the absolute convergence of the infinite products in (4.1) and (4.2) the right-hand sides in (4.4) are well-defined meromorphic functions. They are regular for $|p| < 1$, continuous for $|p| \leq 1$ and similarly for $|q| < 1$ and $|q| \leq 1$, since all their poles are outside the unit disk. The poles in the right-hand sides of (4.4) are all positive, whereas their zeros are all negative. This observation shows that the coefficients in the series expansion in powers of p of the right-hand side of (4.4)(i) are all positive and so $\Phi(p, 0)/\Phi(1, 0)$, $|p| \leq 1$, is the generating function of a probability distribution; similarly for $\Phi(0, q)/\Phi(0, 1)$. Note that the ergodicity conditions (1.4), which have been assumed to apply, imply that $\Phi(1, 0)$ and $\Phi(0, 1)$ are both nonzero. $\Phi(1, 0)$ and $\Phi(0, 1)$ satisfy, cf. (2.5), for $p \rightarrow 1$,

$$\Phi(1, 0) + \left[\frac{d}{dp} Q_1(p) \right]_{p=1}^{-1} \Phi(0, 1) = 0. \tag{4.5}$$

The functions $\Phi(p, 0)$ and $\Phi(0, q)$ satisfy the relation

$$\frac{\Phi(\hat{p}, 0)}{\hat{p} - 1} + \frac{\Phi(0, \hat{q})}{\hat{q} - 1} + \Phi(0, 0) = 0, \tag{4.6}$$

for every zero tuple (\hat{p}, \hat{q}) of $K(p, q)$ with $|p| \leq 1$, $|q| \leq 1$, because of the relation (4.5) between $\Phi(1, 0)$ and $\Phi(0, 1)$, and because they are meromorphic with the same poles and zeros as constructed in the sections 2 and 3 by starting with $|\hat{p}| = 1$, $\hat{q} = Q_1(p)$ and $|\hat{q}| = 1$, $\hat{p} = P_1(\hat{q})$, cf. also (2.29). Whenever $\Phi(p, 0)/\Phi(1, 0)$ and $\Phi(0, q)/\Phi(0, 1)$ are both generating functions of probability distributions on $\{0, 1, 2, \dots\}$ then $\Phi(p, q)$, as determined by (1.6)(i), (ii), for $|p| \leq 1$, $|q| \leq 1$, is necessarily a bivariate generating function of a probability distribution on S because the condition (1.6)(i) is equivalent with the Kolmogorov equations for the (x_n, y_n) -process.

Since this (x_n, y_n) -process is assumed to be ergodic its set of Kolmogorov equations possesses only one absolutely convergent solution, apart from a constant factor. These conditions are equivalent to the conditions (1.6)(i), (ii) and moreover they show that only one function $\Phi(p, q)$, $|p| \leq 1$, $|q| \leq 1$ exists, apart from a constant factor, which satisfies (1.6)(i), (ii).

From the above it is seen that $\Phi(p, 0)/\Phi(1, 0)$ and $\Phi(0, q)/\Phi(0, 1)$ indeed determine a $\Phi(p, q)$ which satisfies the conditions (1.6)(i) and (ii), apart from a constant factor and consequently the statement (4.4) has been proved. \square

Remark 4.1. If $\alpha_0^{(I)} = \alpha_0^{(II)}$, cf. (3.7), then (4.4) also holds and $A^{(II)}(p) \equiv A^{(I)}(p)$ for all p : analogously if $\gamma_0^{(I)} = \gamma_0^{(II)}$ and then $\Gamma^{(I)}(q) = \Gamma^{(II)}(q)$ for all q .

It remains to determine $\Phi(1, 0)$ and $\Phi(0, 1)$. From (1.6) and (2.1), for $q = 1$ we have

$$\{p - \phi(p, 1)\} \Phi(p, 1) = (p - 1)\phi(p, 1)\Phi(0, 1), \quad (4.7)$$

with

$$\phi(p, 1) = [1 - a_1 r_{11}(1 - p)] [1 - a_2 r_{21}(1 - p)]; \quad (4.8)$$

so that

$$p - \phi(p, 1) = p - 1 - (a_1 r_{11} + a_2 r_{21})(p - 1) - a_1 a_2 r_{11} r_{21} (p - 1)^2. \quad (4.9)$$

Hence, from (4.7) and (4.9), after division by $p - 1$ and letting $p \rightarrow 1$, we obtain, since the norming condition requires that $\Phi(1, 1) = 1$,

$$\Phi(0, 1) = 1 - a_1 r_{11} - a_2 r_{21} = 1 - E\{\xi\} > 0, \quad (4.10)$$

and from (4.5) or directly by symmetry, cf. (1.4),

$$\Phi(1, 0) = 1 - a_2 r_{22} - a_1 r_{12} = 1 - E\{\eta\} > 0. \quad (4.11)$$

The functions $\Phi(p, 0)$ and $\Phi(0, q)$ are completely given by (4.4), (4.10) and (4.11). It follows that

$$\begin{aligned} \Phi(0, 0) &= (1 - a_1 r_{11} - a_2 r_{21}) \frac{P^{(I)}(1)P^{(II)}(1)}{A^{(I)}(1)A^{(II)}(1)} \\ &= (1 - a_2 r_{22} - a_1 r_{12}) \frac{Q^{(I)}(1)Q^{(II)}(1)}{\Gamma^{(I)}(1)\Gamma^{(II)}(1)}. \end{aligned} \quad (4.12)$$

Note that the second equality sign in (4.12) formulates an identity for the hyperbola $K(p, q) = 0$, p and q real. It should be noted that (4.4) and (4.12) imply that

$$\Phi(p, 0) = \Phi(0, 0) \frac{A^{(I)}(p)A^{(II)}(p)}{P^{(I)}(p)P^{(II)}(p)}, \quad \Phi(0, q) = \Phi(0, 0) \frac{\Gamma^{(I)}(q)\Gamma^{(II)}(q)}{Q_1^{(I)}(q)Q_2^{(II)}(q)}. \quad (4.13)$$

Remark 4.2. In the first paragraph of this section it has been mentioned that it has not been shown that the zeros of $\Phi(p, 0)$ and $\Phi(0, q)$ constructed in section 3 are the only zeros. From the fact that $\Phi(p, 0)$ and $\Phi(0, q)$ as given by (4.4) and (4.11) is the unique solution it follows that these zeros are the only zeros indeed.

Appendix A

The kernel $K(p, q)$ has been defined in (2.1); we have from (1.3) and (2.1),

$$K(p, q) := pq - [1 - a_1 + a_1(r_{11}p + r_{12}q)] [1 - a_2 + a_2(r_{21}p + r_{22}q)]. \quad (\text{A.1})$$

Obviously, $K(p, q) = 0$ is a conic for real p and q .

Firstly, we show that this conic is a hyperbola because of the ergodicity conditions (1.4).

For the discriminant D of this conic we have

$$D = a_1^2 a_2^2 [r_{11} r_{22} - r_{12} r_{21}]^2 - 2a_1 a_2 (r_{11} r_{22} + r_{12} r_{21}) + 1. \tag{A.2}$$

Some simple algebra shows that: for $r_{11} r_{22} - r_{12} r_{21} \neq 0$,

$$D = (r_{11} r_{22} - r_{12} r_{21})^2 \left[a_1 a_2 - (\sqrt{r_{11} r_{22}} + \sqrt{r_{12} r_{21}})^{-2} \right] \times \left[a_1 a_2 - (\sqrt{r_{11} r_{22}} - \sqrt{r_{12} r_{21}})^{-2} \right]; \tag{A.3}$$

for $r_{11} r_{22} = r_{12} r_{21}$,

$$D = 1 - 4a_1 a_2 r_{11} r_{22}. \tag{A.4}$$

From the ergodicity conditions (1.4) we have: $(a_1 r_{11} + a_2 r_{21})(a_1 r_{12} + a_2 r_{22}) < 1$, or equivalently,

$$\left[a_1 \sqrt{r_{11} r_{12}} \pm a_2 \sqrt{r_{21} r_{22}} \right]^2 + a_1 a_2 \left[\sqrt{r_{11} r_{22}} \mp \sqrt{r_{12} r_{21}} \right]^2 < 1. \tag{A.5}$$

Hence,

$$0 < a_1 a_2 \left[\sqrt{r_{11} r_{22}} \pm \sqrt{r_{12} r_{21}} \right]^2 < 1. \tag{A.6}$$

Consequently, it is seen from (A.3) and (A.6) that $D > 0$ for $r_{11} r_{22} \neq r_{12} r_{21}$.

For $r_{11} r_{22} = r_{12} r_{21}$ we have from (A.5) that $4a_1 a_2 r_{11} r_{22} < 1$ and so (A.4) shows that for this case also holds that $D > 0$. Consequently, the ergodicity conditions (1.4) imply that

$$K(p, q) = 0 \text{ is a hyperbola for real } p \text{ and } q. \tag{A.7}$$

The intersections of this hyperbola with the axes are given by

$$\left(-\frac{1 - a_1}{a_1 r_{11}}, 0 \right), \quad \left(-\frac{1 - a_2}{a_2 r_{21}}, 0 \right), \quad \left(0, -\frac{1 - a_1}{a_1 r_{12}} \right), \quad \left(0, -\frac{1 - a_2}{a_2 r_{22}} \right). \tag{A.8}$$

Further, special points of $K(p, q) = 0$ are

$$(p, q) = (1, 1) = \left(1, \frac{(1 - a_1 r_{12})(1 - a_2 r_{22})}{a_1 a_2 r_{12} r_{22}} \right) \text{ with } \frac{(1 - a_1 r_{12})(1 - a_2 r_{22})}{a_1 a_2 r_{12} r_{22}} > 1, \\ = \left(\frac{(1 - a_2 r_{21})(1 - a_2 r_{11})}{a_1 a_2 r_{21} r_{11}}, 1 \right) \text{ with } \frac{(1 - a_2 r_{21})(1 - a_1 r_{11})}{a_1 a_2 r_{21} r_{11}} > 1; \tag{A.9}$$

the inequalities in (A.9) follow from (1.4).

The asymptotic directions of the hyperbola are given by the zeros z_1 and z_2 of the quadratic equation

$$a_1 a_2 r_{12} r_{22} z^2 + [-1 + a_1 a_2 (r_{11} r_{22} + r_{12} r_{21})] z + a_1 a_2 r_{11} r_{21} = 0. \tag{A.10}$$

From (A.9) we have

$$z_1 z_2 = \frac{r_{11} r_{21}}{r_{22} r_{12}} > 0, \quad (A.11)$$

$$1 > z_1 + z_2 = 1 - a_1 a_2 (r_{11} r_{22} + r_{12} r_{21}) > 0;$$

note that the inequalities in (A.11) follow from, cf. (A.8),

$$a_1 a_2 [\sqrt{r_{11} r_{22}} + \sqrt{r_{12} r_{21}}]^2 < 1.$$

Hence, by defining $z_2 > z_1$ we have

$$z_2 > z_1 > 0, \quad (A.12)$$

i.e., the tangent of the slope of each asymptotic is positive.

In order to locate the position of the two branches of the hyperbola with respect to its asymptotes consider the relations, cf. (A.1) and (A.9),

$$\begin{aligned} K(0, 0) &= -(1 - a_1)(1 - a_2) < 0, & K(1, 1) &= 0, \\ K(1, q) &= q - [1 - a_1 r_{12}(1 - q)] [1 - a_2 r_{22}(1 - q)] \\ &= -a_1 a_2 r_{12} r_{22} (q - 1) \left(q - \frac{(1 - a_1 r_{12})(1 - a_2 r_{22})}{a_1 a_2 r_{12} r_{22}} \right). \end{aligned} \quad (A.13)$$

Hence,

$$K(\hat{p}, \hat{q}) > 0 \quad \text{for } \hat{p} = 1, \quad \hat{q} = \frac{1}{2} \left[1 + \frac{(1 - a_1 r_{12})(1 - a_2 r_{22})}{a_1 a_2 r_{12} r_{22}} \right], \quad (A.14)$$

so that the hyperbola intersects the line through (0, 0) and (\hat{p}, \hat{q}) between these points. This result together with (A.8) and (A.12) shows that one branch of the hyperbola lies completely in the first quadrant and the hyperbola is situated as sketched in figure 7.

So far we have considered $K(p, q)$ for real p and q . Next we consider this function for complex p and q .

With $p = sq$ we have, cf. (2.1),

$$K(sq, q) = 0 \Leftrightarrow s = E\{s^\xi q^{\xi + \eta - 2}\}. \quad (A.15)$$

We have from (1.3)

$$\Pr\{\xi + \eta - 2 \leq 0\} = 1. \quad (A.16)$$

Hence, for $|s| = 1$ and $|q| \geq 1, q \neq 1$,

$$|E\{s^\xi q^{\xi + \eta - 2}\}| < 1.$$

Because $\Pr\{\xi \geq 0\} = 1$ it is seen that the last member in (A.15) is regular for $|s| < 1$, continuous for $|s| \leq 1$ if $|q| \geq 1$. Consequently, application of Rouché's theorem shows that $K(sq, q)$ with $|q| \geq 1, q \neq 1$, has exactly one zero in $|s| < 1$. The equation $K(p, q) = 0$ has for given q two zeros, $P_1(q)$ and $P_2(q)$, say. Denote by $P_1(q)$ the in

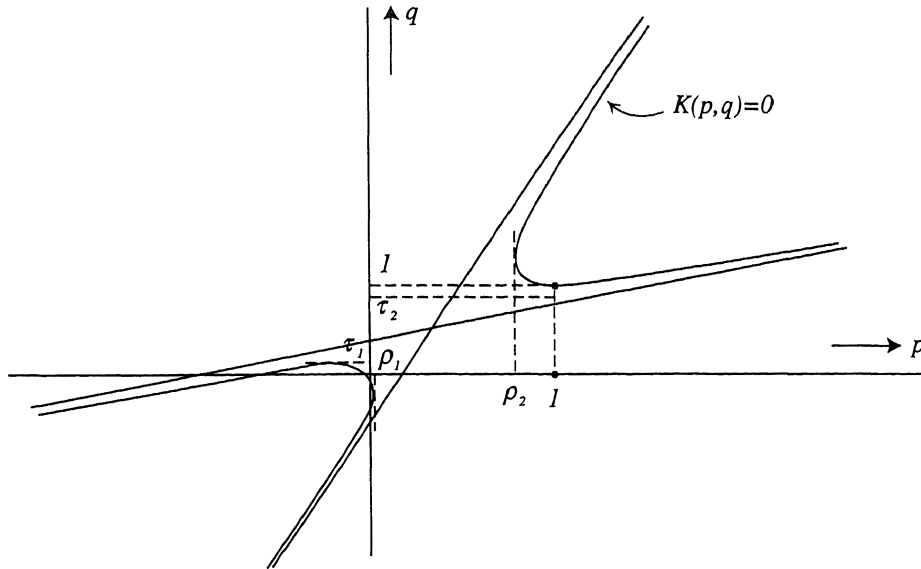

Figure 7.

absolute value smaller one, if their absolute values differ. From the analysis discussed it then follows that for the two zeros holds: for $|q| \geq 1, q \neq 1$,

$$|P_1(q)| < |q| < |P_2(q)|; \tag{A.17}$$

for $q = 1$, see (A.9).

With $Q_{1,2}(p)$ the two zeros of $K(p, q) = 0$ it follows as above that: for $|p| \geq 1, p \neq 1$,

$$|Q_1(p)| < |p| < |Q_2(p)|. \tag{A.18}$$

From (A.9) we have

$$P_1(1) = 1 < P_2(1), \tag{A.19}$$

$$Q_1(1) = 1 < Q_2(1).$$

Because $P_1(q) \neq P_2(q)$ for $|q| \geq 1$, it is seen that if $P_{1,2}(q)$ has branch points, then necessarily they are inside the unit disk, similarly for the branch points of $Q_{1,2}(p)$. From the position of the hyperbola it is seen that

$$\begin{aligned} P_{1,2}(q) \text{ has two branch points } \tau_1 \text{ and } \tau_2, \text{ say,} \\ Q_{1,2}(p) \text{ has two branch points, } \rho_1 \text{ and } \rho_2; \end{aligned} \tag{A.20}$$

and

$$0 \leq \tau_1 < \tau_2 < 1, \quad 0 \leq \rho_1 < \rho_2 < 1, \tag{A.21}$$

and they have no other branch points.

For the zeros $P_{1,2}(q)$ and the zeros $Q_{1,2}(p)$ it is seen from (A.1) that we have

$$\begin{aligned} P_1(q)P_2(q) &= \frac{[1 - a_1(1 - r_{12}q)][1 - a_2(1 - r_{11}q)]}{a_1a_2r_{11}r_{21}}, \\ Q_1(p)Q_2(p) &= \frac{[1 - a_1(1 - r_{11}p)][1 - a_2(1 - r_{21}p)]}{a_1a_2r_{22}r_{12}}. \end{aligned} \quad (\text{A.22})$$

These relations may be used to obtain a recursive algorithm for the determination of the various zeros and poles of $\Phi(p, 0)$ and $\Phi(0, q)$, cf. (4.1), (4.2) and (4.4). E.g., it is seen from the definitions in (2.21) that (A.22) leads to

$$p_{n+1}^{(I)}p_n^{(I)} = \frac{[1 - a_1(1 - r_{12}q_n^{(I)})][1 - a_2(1 - r_{22}q_n^{(I)})]}{a_1a_2r_{11}r_{21}}, \quad (\text{A.23})$$

$$q_{n+1}^{(I)}q_n^{(I)} = \frac{[1 - a_1(1 - r_{11}p_{n+1}^{(I)})][1 - a_2(1 - r_{21}p_{n+1}^{(I)})]}{a_1a_2r_{22}r_{12}}; \quad (\text{A.24})$$

so if $p_n^{(I)}$ and $q_n^{(I)}$ are known then $p_{n+1}^{(I)}$ follows from (A.23), and then $q_{n+1}^{(I)}$ follows from (A.24) since $q_n^{(I)}$ is known and $p_{n+1}^{(I)}$ has just been calculated.

Remark A.1. For the numerical evaluation of infinite products occurring in (4.1) and (4.2) and their derivatives for $p = 1$ and $q = 1$ the reader is referred to the appendix of our study [3].

References

- [1] O.J. Boxma and G.J. Van Houtum, The compensation approach applied to a 2×2 switch, *Probab. Engrg. Inform. Sci.* 7 (1993) 471–493.
- [2] J.W. Cohen, *Analysis of Random Walks* (IOS Press, Amsterdam, 1992).
- [3] J.W. Cohen, On the analysis of the symmetrical shortest queue, Report BS-9420, CWI, Amsterdam (1994).
- [4] J.W. Cohen, On a class of two-dimensional nearest-neighbour random walks, in: *Studies in Applied Probability Theory*, eds. J. Gani and J. Galambos, *J. Appl. Probab.*, special vol. 31A (1994).
- [5] J.W. Cohen, On the determination of the stationary distribution of a symmetric clocked buffered switch, in: *Teletraffic for the Information Age, Proc. of the 15th ITC Congress*, eds. V. Ramaswami and P.E. Wirth (Elsevier, Amsterdam, 1997) pp. 297–308.
- [6] S. Jaffe, The equilibrium distribution for a clocked buffered switch, *Probab. Engrg. Inform. Sci.* 6 (1992) 425–438.
- [7] Z. Nehari, *Conformal Mapping* (Dover, New York, 1952).